

OSO

EXPORT

Saga Supercharged S₂S

-boiler with fully integrated smartcontrol

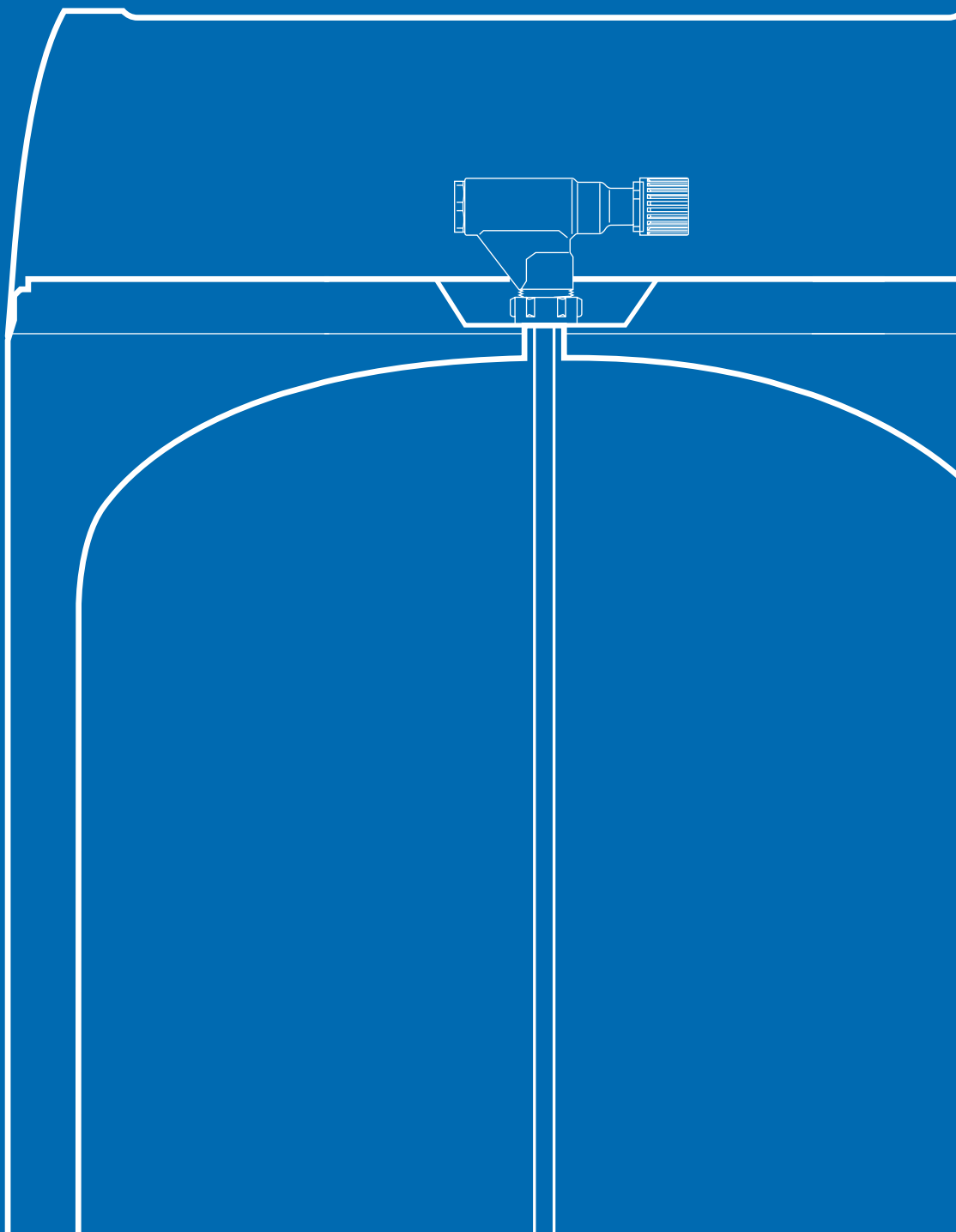

Introducing the Saga 2.0 series:

SAGA SUPERCHARGED

OSO

SAGA 2.0

BEST INSULATION

20% reduced heat loss saves approx. 3 000 kWh during the lifespan

TIMELESS DESIGN

With all valves and connections hidden the Saga 2.0 fits in all environments

SUPERCHARGED

MAXIMIZE SAVINGS

Heating when energy prices are at their lowest significantly reduces costs

COMFORT

Learning your consumption pattern to maximize savings and guarantee Hot Water

SOLAR READY

Serves as a thermal battery in combination with solar panels



SAGA 2.0 SUPERCHARGED - S₂S

Fully integrated OSO CHARGE™ smartcontrol



SAGA 2.0 SUPERCHARGED - S₂S - the most innovative home appliance available on the market, featuring the fully integrated OSO CHARGE™ R3 Smart control system. SUPERCHARGED intelligently learns your hot water usage patterns and optimizes heating during off-peak electricity hours, potentially saving an average family up to €300 annually.

Equipped with advanced sensor technology, it offers complete oversight of capacity and consumption. With the OSO inCHARGE app, you can effortlessly manage your water heater, including features like sleep mode. Additionally, SUPERCHARGED is designed for seamless integration with solar energy systems, enhancing its efficiency and sustainability.

SAGA has been Norway's best-selling boiler for several decades. Modern design hides all pipes and connections. SAGA is easy to install with all pipe connections on top and fits directly as a replacement for OSO water heaters from 1980 to today. The mixing valve lowers the outgoing water temperature and prevents risk of scalding. SAGA has the lowest heat loss on the market, in combination with a high storage temperature for unbeatable performance and more usable hot water.

WHY SAGA SUPERCHARGED?

- Fully integrated CHARGE™ smartcontrol creates big savings on energy bills
- Save up to €300 annually with price optimisation
- Save another 3 000 kWh during the lifespan due to market leading insulation (200 L)

KEY COMPONENTS

Smartcontrol:	OSO CHARGE™ R3
Thermostat:	Adjustable 60-90°C
Mixing valve:	Adjustable 40-75°C
Safety valve:	9 bar, G 3/4" F
Mains cable:	3 m.
Heating element:	G 1.1/4" M / limescale resistant
Appliance feet:	Adjustable 0 - 40 mm.

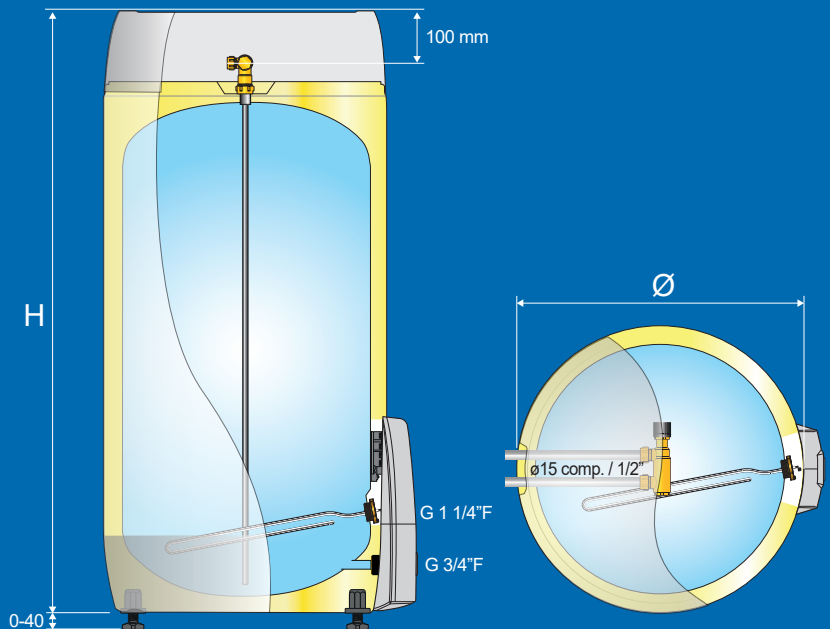

TECHNICAL DATA

OSO No.	Product name	Dia x Height mm.	Cap. pers.	Wt. kg.	Freight vol. m ³	Volume L	Volume L/40 °C	AEC kWh/år	Heat loss W	Therm. set point °C	Ener. eff. %	Rating ErP	Prof. ErP
11013038	S ₂ S 200 - 2.8 kW/1x230V	Ø595x1310	3.5	36	0.48	194	342	4 172	55	Smart	40	C	XL
11011647	S ₂ S 300 - 2.8 kW/1x230V	Ø595x1780	5.5	45	0.64	281	490	4 158	68	Smart	40	C	XL

OSO

World class hot water cylinders since 1932